

Strokmatic
Automation Technology



»» **ACTUADORES**
NEUMÁTICOS
ROTATIVOS.
DE DOBLE EFECTO

PNEUMATIC ACTUATORS

Gears and material

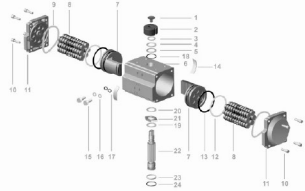

High Technology

Light weight, simply structure, easy maintenance, long working life



High Precision

High precision bearings, high-strength piston, high density output shaft



Very Reliable

Stroke adjustment, flexible opening and closing



Wide range of Adaptability

Replaceable seal, wide temperature adaptability

NO.	Description	Qty	Material	Anti-corrosion treatment	Optional materials	Wearing parts
1	Indicator screw	1	PA66-SS			
2	Indicator	1	PDM			
3	Spring clip	1	Stainless steel			
4	Gasket	1	Stainless steel			
5	Outer gasket	1	PTFE			
6	Cylinder body	1	6005-T5	Hard anodizing etc.		
7	Piston	2	Cast aluminum	Hard anodizing	Stainless steel	
8	Spring assembly	*	60Si2Mn2-PA66	Dip coating		
9	End cap O-ring	2	NBR/HNBR/FKM		Viton/silicone	X
10	Cap screw	8	Stainless steel			
11	End cap	2	Cast aluminum	Powder spray etc.		
12	Bearing (piston)	2	NBR/HNBR/FKM			
13	End cap O-ring	2	NBR/HNBR/FKM		Viton/silicone	X
14	Piston bushing	2	PDM		PTFE	
15	Adjusting bolt	2	Stainless steel			
16	Adjusting screw nut	2	Stainless steel			
17	Adjusting nut (adjusting nut)	2	NBR/HNBR/FKM		Viton/silicone	
18	O-ring (piston top)	1	NBR/HNBR/FKM		Viton/silicone	X
19	Bearing (piston top)	1	PTFE			X
20	Inner gasket	1	PTFE			
21	Hexagon block	1	Stainless iron			
22	Gear shaft	1	Alloy steel	Nickel plated	Stainless steel	
23	Bearing (piston bottom)	1	PTFE			
24	O-ring (piston bottom)	1	NBR/HNBR/FKM		VITON	X



MODELO: SRAT

SRAT single-acting actuator torque

		Output torque of air supply (N·m)												Spring stroke (mm)				
Air pressure (bar)		3			4			5			6			7				
Model	Spring Qty	0°	90°	0°	90°	0°	90°	0°	90°	0°	90°	0°	90°	0°	90°	0°	90°	
		Start	end	Start	end	Start	end	Start	end	Start	end	Start	end	Start	end	Start	end	
SRAT-52-SA	5	8.48	6.28	12.64	10.44											4	6.2	
	6	7.68	4.98	11.84	9.14											4.8	7.5	
	7	6.98	3.78	11.14	7.94											5.5	8.7	
	8			10.34	6.74	14.5	10.9									6.3	9.9	
	9			9.54	5.44	13.7	9.6									7.1	11.2	
	10			8.74	4.24	12.9	8.4	17.06	12.56							7.9	12.4	
SRAT-63-SA	11					12.1	7.1	16.26	11.26	20.42	15.42	8.7	13.7					
	12					11.3	5.9	15.46	10.06	19.62	14.22	9.5	14.9					
	5	11.5	11.2	22.3	18.5	29.6	25.8							7	10.8			
	6	13.5	9	20.8	16.3	28.1	23.7							8.5	12.95			
	7	12	6.9	19.4	14.2	26.7	21.5							9.9	15.1			
	8	18	12	25.3	19.3	32.6	26.6							11.3	17.3			
SRAT-83-SA	9			16.5	9.9	23.9	17.2	31.2	24.52					12.7	19.4			
	10			15.3	7.7	22.6	15	29.9	22.3	37.2	29.6	14	21.6					
	11					32.7	20.3	44.4	32	56.2	43.8	26.1	38.5					
	12					30.4	16.8	42.1	28.5	53.9	40.3	28.4	42					
	5	30.9	23.8	46.1	38.9									14.5	21.7			
	6	28.1	19.5	43.3	34.6									17.39	26			
SRAT-83-SA	7	25.2	18.1	40.3	30.2									20.3	30.4			
	8			37.4	25.9	52.6	41.1							23.2	34.7			
	9			34.5	21.5	49.7	36.7							26.1	39.1			
	10			31.6	17.2	46.8	32.4	62	47.6	77.1	62.7	29	43.4					
	11					43.9	28.1	59.1	43.3	74.2	58.4	31.9	47.7					
	12					41	23.7	56.2	38.8	71.3	54	34.78	52.08					

Graphic

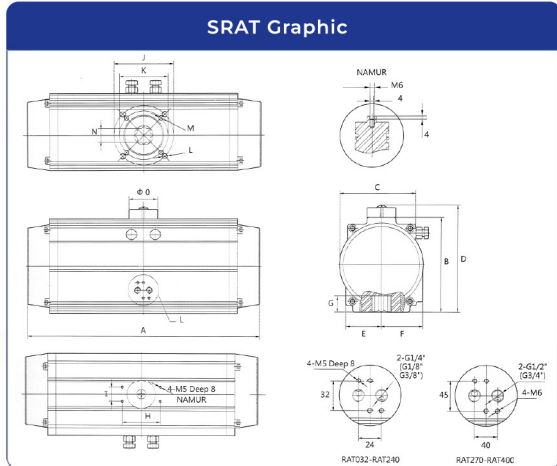

Model	A	B	C	D	E	F	G	H	I
SRAT-52	163.5	72	65	98	26	42	14	80	30
SRAT-63	181	87.6	91.6	134.5	40	56.5	18	80	30
SRAT-83	213	108.9	91.6	134.5	40	56.5	21	80	30

Model	J	K	L	M	N	O	Input thread pore
SRAT-52	F05/Φ50	F03/Φ36	M6x9	M5x8	11	Φ40	G1/4"
SRAT-63	F07/Φ70	F05/Φ50	MBx10	M6x9	14	Φ40	G1/4"
SRAT-83	F07/Φ70	F05/Φ50	MBx12	M6x9	17	Φ40	G1/4"

Note: A120, A180 stands for the angular stroke of 120° and 180° respectively

Installation and application

1. Must clean up the inside of pneumatic actuator. If there is any impurity exists in the fluid, please install the filter valve on the pipeline.
2. When installing pneumatic actuators, ensure the time required for maintenance and disassembly of various components.
3. The window must not collide with hard objects.
4. Check the model and parameters of pneumatic actuator whether it meet the technical requirements for on-site installation.
5. Check the cylinder and position indicator of pneumatic actuator, ensure there is no damage.
6. If a solenoid valve is installed, the joint should be well sealed.

Model: SRAT083-DA

Model: SRAT052-DA

Model: SRAT063-DA

SRAT double-acting actuator output torque

	Input gas source (bar)							
	2	3	4	5	6	7	8	
SRAT-52-DA	4.44	6.56	9.83	11.72	14.06	15.63	17.97	
SRAT-63-DA	14.64	21.96	29.28	36.6	43.92	51.24	58.56	
SRAT-83-DA	29.7	44.5	59.4	74.2	89.1	103.9	118.8	



Back View



Suggested use*
*Namur valve not included

NAMUR Valve*
*Sold separately

Airtac®

Model: 4M310-08
Pressure: 0.15-0.8 MPa

